

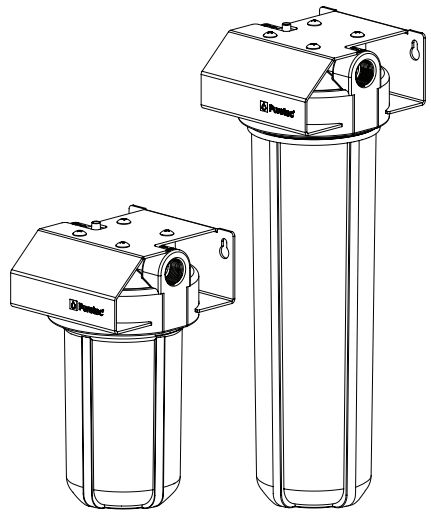

Puretec[®]
PERFECTING WATER

⚠ CAUTION

**DO NOT OVERTIGHTEN.
DO NOT USE
LIQUID SEALANTS.**



User Guide

MPX Series

High Capacity Filter Housings



WaterMark

AS/NZS 3497

Licence No. WM 74617

Australian Certification Services

What's Inside

Introduction.....	2
Guidelines and Warnings.....	3
Positioning Your Filter.....	3
Installation Procedure.....	4
Typical Installation.....	4
Replacement Guide.....	5
Cartridge Installation / Replacement.....	5
Replacement Parts List.....	6
Warranty.....	7

Puretec Customer Service

Thank you for purchasing a Puretec High Flow Water Filter Housing. Your system is a proven performer manufactured from only quality materials and components and will give years of 'spring fresh' water free of impurities if maintained properly.

The system is designed for mains or rainwater supply but can be used in other situations. For other types of water supply please contact your local Puretec stockist or call our Puretec Customer Service Helpline.

The Puretec filter systems cartridges need replacing regularly to maintain optimum performance. This is a simple procedure when following instructions. For cartridge replacements contact your nearest Puretec stockist.

Customer Service Helpline **1300 140 140** (Australia) **0800 130 140** (New Zealand).

Guidelines and Warnings

- System Max Pressure Rating : 900 kPa

Note: Where line pressure exceeds 500 kPa, an approved pressure limiting device must be installed to comply with Australian & New Zealand Plumbing Standards. (Ref. AS/NZS 3500.1:2021, Clause 3.3.4).
- Protect the housing from water hammer.
- Use on cold water line only (with water up to 52°C). For installation over 52°C please enquire as to a suitable housing. Protect the housing from freezing.
- Avoid installing in direct sunlight.
- **Use PTFE thread seal tape on all connections. Use of pipe sealants will void warranty.**
- Do not overtighten. Too much tape or over tightening may cause head to split.
- For point of entry installations an approved dual check backflow prevention device must be fitted in accordance with national plumbing product codes.
- Do not use with water that is microbiologically unsafe or with water of unknown quality without adequate disinfection.
- This product must be installed in accordance with local plumbing regulations by a licensed plumber.

Installation Note: A water filter system/tap, like any product, has a limited life and may eventually fail. Also sometimes failure happens early due to unforeseen circumstances. To avoid possible property damage, this product should be regularly examined for leakage and/or deterioration and replaced when necessary. A drain pan, plumbed to an appropriate drain or outfitted with a leak detector, should be used in those applications where any leakage could cause property damage, and/or the water supply should be turned off if no one is home/present.

INSTALLATION MUST BE COMPLETED BY A LICENCED PLUMBER. FAULTY OPERATION DUE TO UNQUALIFIED PERSONS WILL RESULT IN VOIDED WARRANTY COVERAGE.

Positioning Your Filter

Choose a location where any water spillage will not cause damage. Make sure mounting position is solid so that the filter housing stays in position when changing filters. An isolation valve may be installed immediately prior to the filter to isolate the filter for changing the cartridge.

Installation Procedure

1. Isolate water supply and relieve pressure by opening a downstream tap.
2. Cut pipe to suit length of required valve and housing installation.
3. Use approved brass, galv/poly plumbing fittings to suit existing pipework. The female threads on the housing will receive tapered male threads. Thread into housing head carefully as too much tape or overtightening may cause it to split.

Warning: Use PTFE thread seal tape on all connections. Use of pipe sealants will void warranty.

4. If using sweated fittings, allow enough time to cool before connecting to the housing.
5. Securely fix wall mount bracket (see inclosed mounting guide) and pipework with suitable clips. Allow 50mm clearance under the bowl for filter changes.
6. Flush debris from pipework.
7. Install filter cartridge (not included) as per cartridge replacement instructions (pg.5).

Typical Installation

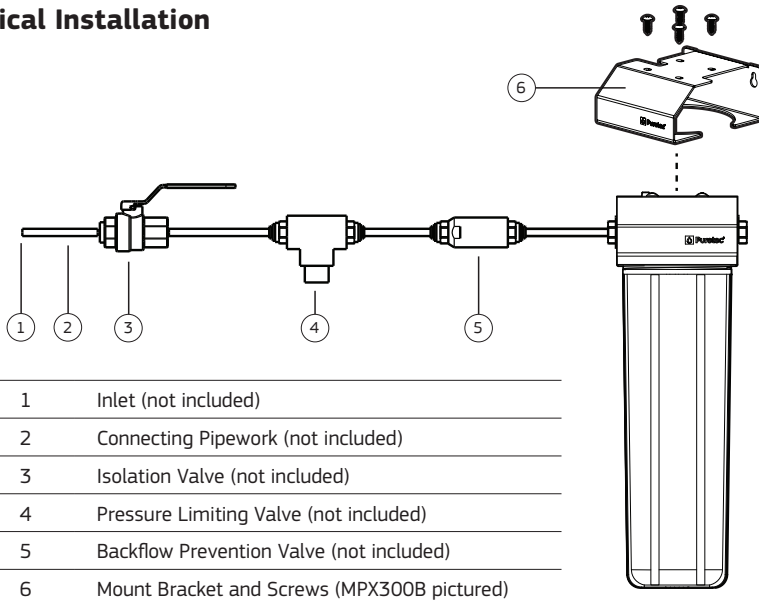

Replacement Guide

You can obtain replacements from your local Puretec dealer. To maintain performance, warranty and standards use genuine Puretec replacements.

MPX Housings

Model Code	Dirt, Rust, Sediment (Mains Water)	Taste, Odour Removal (Mains Water)	Dirt, Rust, Sediment (Rainwater)	Taste, Odour Removal (Rainwater)
MPX100B	PX05MP1	CB10MP1	PL05MP1	DP10MP1
MPX300B	PX05MP2	CB10MP2	PL05MP2	DP10MP2

To maintain the high quality of the purified water the cartridge needs changing every 6 - 12 months (this is dependent on water quality and usage). You can obtain replacement cartridges from your local Puretec stockist. To maintain performance and warranty use genuine Puretec replacements.

Cartridge Installation / Replacement

To change the filter cartridge please adhere to the following procedure:

- 1 Turn water supply off and relieve pressure by opening a downstream tap or pressing the red pressure relief button on the housing (if fitted).
- 2 Unscrew the filter bowl. If difficult to undo, use the wrench provided. Remove old cartridge. We recommend replacing O-rings every 3 - 5 years to ensure a water tight seal, preventing any leaks.
- 3 Clean bowl with soap and warm water and rinse thoroughly. Check O-Ring for damage and if there is any, replace.
- 4 Check O-ring lubrication and if necessary apply a light coating of food grade silicone lubricant (or similar).
- 5 Remove all packaging from new filter cartridge and insert into housing bowl making sure cartridge is properly seated over spigot in base of bowl. Remember to record the model number of the cartridge you use.
- 6 Hold bowl upright while screwing onto head. Make certain that the spigot in the housing head is located centrally to the cartridge to make a good seal. Hand tighten bowl until firm. DO NOT OVER TIGHTEN.
- 7 Open downstream tap to allow air to be released and gently open water supply allowing all air to be purged.

- 8 Allow water to run for 2 minutes to flush the system.
- 9 Close down stream tap and check for leaks. Flush system for 10 minutes after any period of non-use more than 2 days. For a period of non-use of 2 weeks or more, it may be necessary to replace the cartridge.

Replacement Parts List

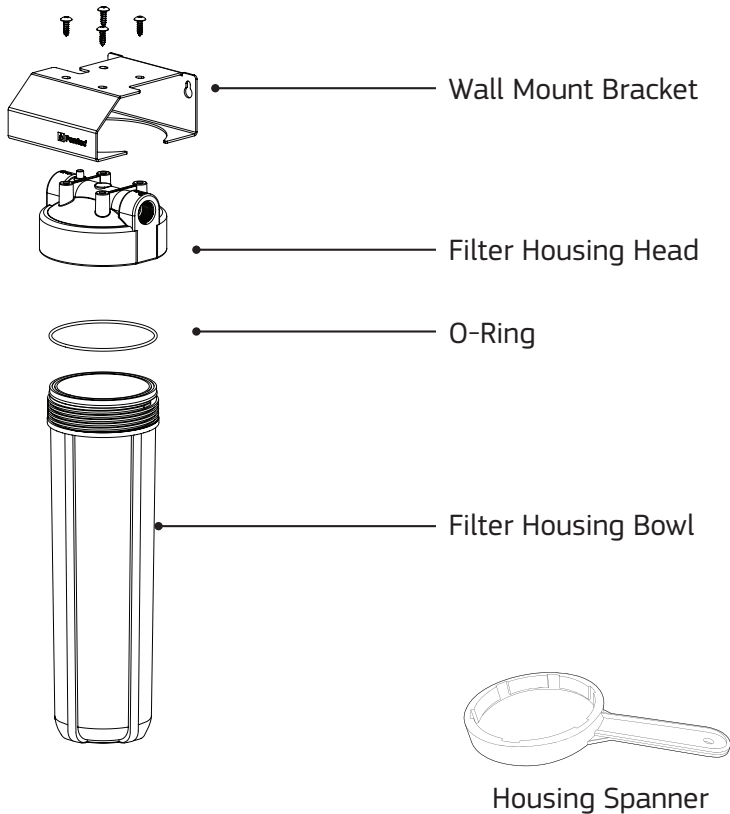

Notes

Puretec water care products are designed, manufactured and supported by Puretec Pty Ltd the name you can trust for viable and proven water solutions. The complete range of Puretec products are developed, refined, made to meet and exceed stringent specifications for the worldwide market.

Important: Sales of products are subject to our Terms and Conditions which are available upon request. All specifications, information and photos are a guide only and are subject to change without notice. Please ring to confirm details. Warning: For correct operation of this appliance it is essential to observe manufacturer's instructions.

Warranty

Any claim under this warranty must be made within 10 years of the date of purchase of the product. This product is warranted to be free of defect of material and workmanship for 10 years from date of purchase. 10 year warranty is 1 year parts and labour, plus 9 years parts only.

Puretec is renowned for its quality and after-sales support so if you have any issues please call 1300 140 140 (AU) or 0800 130 140 (NZ). To make a warranty claim, contact us directly or the place of original purchase. All costs relating to a warranty claim must be approved by Puretec prior to any work being carried out.

Puretec will pay your reasonable, direct expenses of claiming under this warranty. You may submit details and proof of your expense claim to place of purchase for consideration.

The warranty only applies if the product was used and/or installed in accordance with the user guide and/or installation instructions. This warranty is given in lieu of all other express or implied warranties and manufacturer shall in no circumstance be held liable for damages consequential or otherwise or delays caused or faulty manufacturing except as excluded by law.

Applicable to all above, is that the Warranties need to be approved by Puretec to ensure product was not incorrectly used, installed or claimed. False and incorrect claims will be pursued at Puretec's discretion, including chargeable inspection and labour costs incurred.

All installation and service work should be completed by qualified tradespeople. Faulty operation due to unqualified persons will result in voided warranty coverage.

Warranty/Australia

This warranty is given by Puretec Pty Ltd, ABN 44 164 806 688, 37-43 Brodie Road, Lonsdale SA 5160, telephone no. 1300 140 140 and email at sales@puretec.com.au.

This warranty is provided in addition to other rights and remedies you have under law: Our goods come with guarantees which cannot be excluded under the Australian Consumer Law. You are entitled to replacement or refund for a major failure and to compensation for other reasonably foreseeable loss or damage. You are also entitled to have the goods repaired or replaced if the goods fail to be of acceptable quality and the failure does not amount to a major failure.

Warranty/New Zealand

This warranty is given by Puretec Ltd, Reg. No 4464398, PO Box 875 Cambridge 3450 NZ, telephone no. 0800 130 140 and email at sales@puretec.co.nz.

This warranty is provided in addition to other rights and remedies you have under law: Our goods come with guarantees which cannot be excluded under the Consumer Guarantees Act. You are entitled to replacement or refund for a major failure and to compensation for other reasonably foreseeable loss or damage. You are also entitled to have the goods repaired or replaced if the goods fail to be of acceptable quality and the failure does not amount to a major failure.



AUSTRALIA

P 1300 140 140

E sales@puretec.com.au

W puretec.com.au

NEW ZEALAND

P 0800 130 140

E sales@puretec.co.nz

W puretec.co.nz